



motorola



# USER'S GUIDE

**Dashboard Camera**

**Model: MDC400**

*The features described in this user's guide are subject to modifications without prior notice.*

# **Welcome...**

***to your new Motorola Dashboard Camera!***

Thank you for purchasing the Dashboard Camera. Please keep your original dated sales receipt for your records. For warranty service of your Motorola product, you will need to provide a copy of your dated sales receipt to confirm warranty status. Registration is not required for warranty coverage.

For product related questions, please call:

**US and Canada 1-888-331-3383**

**E-mail: [support@motorolastore.com](mailto:support@motorolastore.com)**

**On the Web: [www.motorolastore.com/support](http://www.motorolastore.com/support)**

---

This User's Guide has all the information you need to make the most out of your product.

Please read the Safety Instructions on page 5 before you install the unit.

Before you use the Dashboard Camera, we recommend you insert a SD card into the SD card slot.

## **Got everything?**

- Dashboard Camera
- Windshield Mount
- Car Adapter
- User Manual

# Overview of your Dashboard Camera

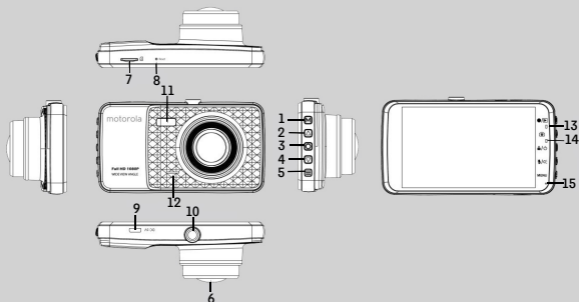

- 1. Mode Button**  
Video/ Replay mode switcher
- 2. Up Button**  
Rewind during playback;  
Short press when in Video mode: Take photo
- 3. OK Button**  
Short press when in Video mode: Lock current video;  
Long press : Turn On/Off
- 4. Down Button**  
Fast forward during playback;  
Short press when recording: Mute;  
Long press when recording: LED On/Off
- 5. Menu/Back Button**  
Setting switcher/Back
- 6. Lens**
- 7. Micro SD card slot**
- 8. Reset Button**
- 9. USB/Power socket**
- 10. Mount Nut**
- 11. LED lights**
- 12. Speaker**
- 13. Charge Indicators**  
Red: Charging  
Green: Fully charged
- 14. Status Light**  
Blue: Power On  
Blue flashing: Recording
- 15. Microphone**

# Table of contents

---

<b>1. Safety Instructions</b> .....	<b>5</b>
<b>2. Getting Started</b> .....	<b>6</b>
2.1 Installing your Device .....	6
2.2 First Use .....	7
<b>3. Using your Dashboard Camera</b> .....	<b>8</b>
3.1 Recording and Saving .....	8
3.2 Switching Modes .....	9
3.2.1 Mass Storage Mode .....	9
3.2.2 Video Mode .....	9
3.2.3 Playback Mode .....	11
3.3 Parking Mode .....	14
3.4 Lock/Unlock the Video .....	14
3.5 Motion Detection .....	15
<b>4. Settings</b> .....	<b>16</b>
4.1 Main Settings .....	16
4.2 Video Settings .....	18
4.3 Photo Settings .....	21
4.4 Playback Settings 23	
<b>5. Disposal of the Device (Environment)</b> .....	<b>24</b>
<b>6. General Information</b> .....	<b>25</b>
<b>7. Technical Specifications</b> .....	<b>32</b>

# 1. Safety Instructions



## **WARNING**

- Do not install the device within the driver's or passenger airbag operation range. Please refer to your car's service manual for details about the operation range of your car's airbags.
- Never modify modes, settings, or program your device while your car is in motion.
- Ensure the device and its power cord are installed as per the instructions on page 6, and do not obstruct the driver's line of sight or impede the operation of any driving controls

## 2. Getting Started

### 2.1 Installing your Device

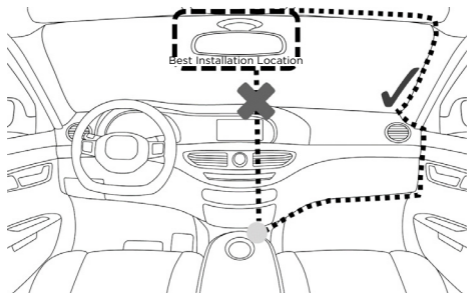

*The above illustration refers to a left-hand drive car. For right-hand drive cars, please flip the position of the cable installation accordingly.*

- Install your device within the rear-view mirror area and within the wiper cleaning area to get the clearest possible view.
- Your device comes with a 3.6m USB power cable. Organise the power cord so that it does not interfere with the driver's vision. Use cable clips to secure the power cord if necessary.
- Place the device on the windshield mount first. Press the suction cup of the mount to the windshield and press the lever to lock. Ensure the mount is safely attached to the windshield.

- When using the dashboard camera device in your car, we recommend that you always use the cigarette charger in order to maintain the battery level. The unit is not designed to run on battery power alone, the battery is there for backup purposes only.

## 2.2 First Use

- Insert a SD card (not provided) in the SD card slot. Your dashboard camera accepts SD cards of up to 32GB capacity (class 10). It is recommended that you format the SD card. Please refer to the settings described in this manual.
- Your dashboard camera will always power up and begin recording automatically as soon as it is connected to a power source.  
Simply connect your dashboard camera to a power source that comes on when you start the engine of your vehicle, and the dashboard camera will start recording automatically without you having to remember to press on a button.
- You can also power it ON or OFF manually by pressing the **OK** button.
- The power LED (Red) will turn ON when the power is plugged in. Whenever the device is turned ON or OFF, you will see a splash screen showing the Motorola logo.

## ***3. Using your Dashboard Camera***

### **3.1 Recording and Saving**

The purpose of your dashboard camera is to continuously record the road ahead, and to automatically record and save any incidents or accidents you might be involved in.

Your device records video by clusters of 1 minute (the duration can be changed in video settings menu, see **4.2 Video Settings**). It is equipped with a sensor that detects shocks. Each time a shock is detected, it will permanently save the cluster during which the event occurred. The sensitivity of the sensor can be changed in the video settings menu, see **4.2 Video Settings**.

Once your SD card is full, it will automatically overwrite the oldest footage. SD card storage space has been set to: 10% for Detection, 20% for Event, 60% for Normal, 10% for Photo.



## 3.2 Switching Modes

You can switch between **Video** and **Playback** mode by pressing the **Mode** button. **Video mode** is the default mode. To view or delete saved photographs, switch to **Playback mode**.

### **IMPORTANT!**

*The driver must never switch modes while the car is in motion.*



### 3.2.1 Mass Storage Mode

You can also connect the device to your computer using the standard micro USB cable to view and manage photos and videos stored inside the SD card.

### 3.2.2 Video Mode

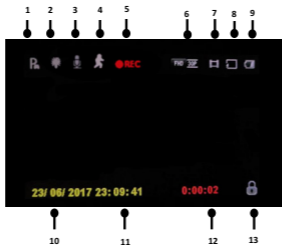
The table below explains the various information displayed on the screen when your MDC400 is in Video mode. Some icons will only be displayed once the relevant function has been selected within the Video menu, as described below.



1. Parking Mode	Appears on screen when Parking Mode has been turned on.
2. LED lights	Appears on screen when LED lights have been turned on
3. Microphone	Appears on screen when Audio Recording is active.  is displayed when the microphone muted.
4. Motion Detection	Appears on screen when Motion Detection has been turned on.
5. Recording	Appears on screen when recording is in progress.  is displayed when in standby.
6. Resolution and Frame	Displays the current resolution and the number of frames per second.
7. Mode	Indicates that the dashboard camera is in Video mode.
8. Memory Card	Indicates whether a memory card is present.  is displayed when the memory card has been removed.
9. Battery	Indicates the battery status.
10. Date	Current date
11. Time	Current time

<b>12. Recording Time</b>	Displays recording time of current video.
<b>13. Protected</b>	Shown on screen when a video file has been protected by activation of the G Sensor or by the pressing of the file protect button.

### 3.2.3 Playback Mode

Press the **Mode** button to select **Playback mode**.

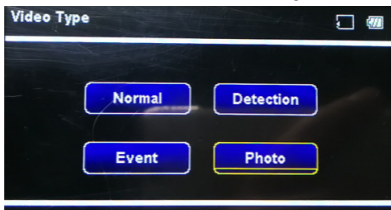

For each Video Type, press **Up** or **Down** to navigate, **OK** to confirm, **Menu/Back** to go to **Playback Setting**, and **Mode** to go back.

Once you have selected a type of video, the following

screen will be displayed.

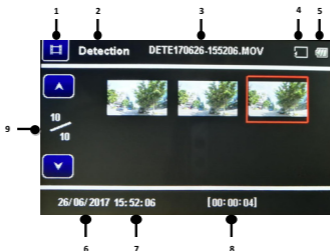

The MDC400 will display the last recorded file. Depending on the type of file, the on-screen information and playback functions differ.

### Video Files:

1. Mode	Indicates that the dashboard camera is in Video Playback mode.
2. Video Type	Indicates whether a Normal, Detection or Event video is being viewed.
3. Video Number	Displays the current video number.
4. Memory Card	Indicates whether a memory card is present.  is displayed when the memory card has been removed.
5. Battery	Indicates the battery status.
6. Date	Current video date.
7. Time	Current video time.

8. Video Length	Current video length.
9. Page	Current page/total page.

### Photo Files:

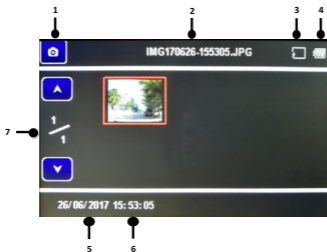

1. Mode	Indicates that the dashboard camera is in Photo Playback mode.
2. Photo Number	Displays current photo number.
3. Memory Card	Indicates whether a memory card is present.  is displayed when the memory card has been removed.
4. Battery	Indicates the battery status.
5. Date	Current photo date.
6. Time	Current photo time.
7. Page	Current page/total page.



### 3.3 Parking Mode

Your dashboard camera can record footages of events occurring when your car is parked with engine off. The built-in battery will keep the sensor of your device in stand-by mode, and will start recording automatically for 30 seconds if it detects vibration or shock. Parking mode can only record and save a footage after an event has been detected by the sensor.

#### ***IMPORTANT!***

*Due to technical reasons, **Parking mode** is disabled by default. You can enable it in video settings menu, see*

#### **4.2 Video Settings**

### 3.4 Lock/Unlock the Video

In case of emergency, you can lock/unlock the current video by pressing on the **OK** button when recording. The video footage of the locked video will be saved in the **Event folder** until the folder is full.

## 3.5 Motion Detection

To save storage space on your SD card, you can enable motion detection. When enabled, the device will stop recording when it does not detect motion for more than 10 seconds. The video footage of the detection video will be saved in the **Detection folder** until the folder is full.

### ***IMPORTANT!***

*This option is disabled by default; enabling it might cause the camera not to record or save part of an incident or accident you might be involved in.*

## 4. Settings

### 4.1 Main Settings

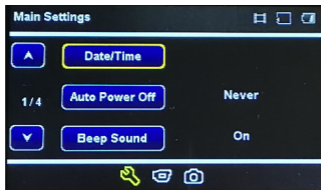

To access **Main Settings**, press the **Menu/Back** button while in **Video** mode.

For each sub-menu, press **Up** or **Down** to navigate, **OK** to confirm, and **Menu/Back** to go back or cancel.

Menu	Description
Date/Time	Set the date and time. Press <b>Up</b> or <b>Down</b> to set each value; press <b>OK</b> to switch to the next value.
Beep Sound	Enable or disable beep sounds.
Language	<b>English/France/Espanol/Portugues/Deutsch/Italiano/简体中文/繁体中文/Russian/Japanese</b>
Frequency	Select exposure, used to adjust exposure level for different light conditions. Set by default to 50Hz; you can set it to 60Hz if you reside in the USA.



<b>LCD Off</b>	You can set the LCD to never turn off or turn off after 3 minutes
<b>Volume</b>	Set the volume of the built-in speaker to <b>high/middle/low</b> .
<b>Format</b>	Use this option to format your SD Card.  IMPORTANT! Formatting a SD card will erase all its memory contents.
<b>Default Setting</b>	Reset all your device settings to factory default.
<b>Stamp Setting</b>	Enable or disable a date stamp showing on your videos and photos.
<b>Version</b>	Current firmware version.

## 4.2 Video Settings

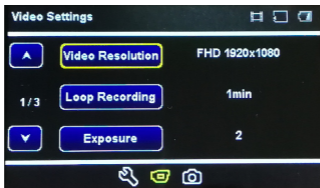

There are two ways to access **Video Settings**:

1. Press the **Menu/Back** button twice while in **Video mode**;
2. Press the **Down** button while in the last sub-menu of **Main Settings**.

For each sub-menu, press **Up** or **Down** to navigate, **OK** to confirm, and **Menu/Back** to go back or cancel.

Menu	Description
Video resolution	<p>You can set the video resolution to: <b>1080FHD 1920*1080, 1080P 1440*1080 or 720P 1280*720</b></p> <p>IMPORTANT! If you want to store more photos or videos on your SD card, try reducing the resolution.</p>

<b>Loop Recording</b>	<p>Loop Recording allows your camera to overwrite old files with new files. Once the memory card becomes full, the camera will delete the first video file to make room for the latest file. Choose the default duration for each recording cluster: <b>1 Minute / 3 Minutes / 5 Minutes / Off</b></p>
<b>Exposure</b>	<p>Used to adjust exposure level for different light conditions. You can adjust the exposure as you require. Press the <b>Up</b> button if you need the photos to be clearer or <b>Down</b> button if you need it to be darker.</p>
<b>Motion Detection</b>	<p>Enable or disable motion detection</p>
<b>G-Sensor</b>	<p>G Sensor detects forces which will automatically protect the current recording in the event of a collision. You can change the sensitivity of the sensor. It is set to <b>Low</b> by default, but can be set to <b>Off/High/Medium/Low</b>. If you turn the sensor off, your dashboard camera will not be able to permanently save any footage.</p>
<b>Park mode</b>	<p>Enable or disable parking mode.</p>
<b>Record audio</b>	<p>Enable or disable microphone.</p>

**IMPORTANT!**

*Changing the video quality and resolution settings to a lower value might reduce the amount of details you can see on your saved videos.*

Resolution	Card Capacity	Recording time (minutes)
<b>1080FHD 1920*1080</b>	4GB	20
	8GB	40
	16GB	80
	32GB	160
<b>1080P 1440*1080</b>	4GB	30
	8GB	60
	16GB	90
	32GB	180
<b>720P 1280*720</b>	4GB	40
	8GB	80
	16GB	160
	32GB	320

**IMPORTANT!**

*The above information is for your reference only. Different memory cards have slightly different total capacity and the maximum recording time is different.*

## 4.3 Photo Settings



There are two ways to access **Photo Settings**:

1. Press the **Menu/Back** button three times while in **Video mode**;
2. Press the **Down** button while in the last sub-menu of **Video Settings**.

For each sub-menu, press **Up** or **Down** to navigate, **OK** to confirm, and **Menu/Back** to go back or cancel.

Menu	Description
Photo Resolution	<p>You can set the photo resolution to <b>12M pixels</b>, <b>8M pixels</b> or <b>5M pixels</b>.</p> <p><i><b>IMPORTANT!</b> If you want to store more photos or videos on your SD card, try reducing the resolution.</i></p>
Image Quality	<p>You can set the photo quality to <b>Fine</b>, <b>Normal</b> or <b>Economy</b>.</p>

<b>White Balance</b>	Adjust the white balance for different light conditions. You can set the white balance to <b>Auto/ Incandescent/Sunny/ Cloudy/ Fluorescent</b> . We recommend to leave it as <b>Auto</b> .
<b>Exposure</b>	Adjust exposure level for different light conditions. You can adjust the exposure as you require. Press the <b>Up</b> button if you need the photos to be clearer or <b>Down</b> button if you need it to be darker.

***IMPORTANT!***

*Changing the photo quality and resolution settings to a lower value might reduce the amount of details you can see on your saved photos*

## 4.4 Playback Settings

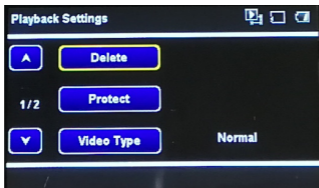

To access **Playback Settings**, press the **Menu/Back** button while in **Playback** mode. For each sub-menu, press **Up** or **Down** to navigate, **OK** to confirm, and **Menu/Back** to go back or cancel.

Menu	Description
<b>Delete</b>	Use this option to delete photos and videos stored in your SD card. You can choose between deleting the current file you are currently watching, or all files on your SD card. <b><i>IMPORTANT! You cannot recover a photo or video that has been previously deleted.</i></b>
<b>Protect</b>	Use this option to lock photos and videos stored in your SD card so that they cannot be deleted. Use the same option to unlock previously locked photos or videos. You can choose between <b>Lock Current</b> , <b>Unlock Current</b> , <b>Lock All</b> or <b>Unlock All</b> .

## ***5. Disposal of the Device (Environment)***

At the end of the product life cycle, you should not dispose of this product with normal household waste. Take this product to a collection point for the recycling of electrical and electronic equipment. The symbol on the product, user's guide and/or box indicates this.



Some of the product materials can be re-used if you take them to a recycling point. By reusing some parts or raw materials from used products you make an important contribution to the protection of the environment.

Please contact your local authorities in case you need more information on the collection points in your area.

Dispose of the battery pack in an environmentally-friendly manner according to your local regulations.



## 6. General Information

If your product is not working properly....

1. Read this User's Guide.
2. Visit our website: [www.motorolastore.com/support](http://www.motorolastore.com/support)
3. Contact Customer Service at

US and Canada 1-888-331-3383

E-mail: [support@motorolastore.com](mailto:support@motorolastore.com)

### **Consumer Products and Accessories Limited Warranty ("Warranty")**

Thank you for purchasing this Motorola branded product manufactured under license by Binatone Electronics International Ltd ("BINATONE").

#### ***What Does this Warranty Cover?***

Subject to the exclusions contained below, BINATONE warrants that this Motorola branded product ("Product") or certified accessory ("Accessory") sold for use with this product is manufactured to be free from defects in materials and workmanship under normal consumer usage for the period outlined below. This Warranty is your exclusive warranty and is not transferable.

THIS WARRANTY GIVES YOU SPECIFIC LEGAL RIGHTS, AND YOU MAY HAVE OTHER RIGHTS THAT VARY BY STATE, PROVINCE OR COUNTRY. FOR CONSUMERS WHO ARE COVERED BY CONSUMER PROTECTION LAWS OR REGULATIONS IN THEIR COUNTRY OF PURCHASE OR, IF DIFFERENT, THEIR COUNTRY OF RESIDENCE, THE BENEFITS CONFERRED BY THIS LIMITED WARRANTY ARE IN ADDITION TO ALL RIGHTS AND REMEDIES

CONVEYED BY SUCH CONSUMER PROTECTION LAWS AND REGULATIONS. FOR A FULL UNDERSTANDING OF YOUR RIGHTS YOU SHOULD CONSULT THE LAWS OF YOUR COUNTRY, PROVINCE OR STATE.

### ***Who is covered?***

This Warranty extends only to the first consumer purchaser, and is not transferable.

### ***What will BINATONE do?***

BINATONE or its authorized distributor at its option and within a commercially reasonable time, will at no charge repair or replace any Products or Accessories that does not conform to this Warranty. We may use functionally equivalent reconditioned/ refurbished/ pre-owned or new Products, Accessories or parts.

### ***What Other Limitations Are There?***

ANY IMPLIED WARRANTIES, INCLUDING WITHOUT LIMITATION THE IMPLIED WARRANTIES OF MERCHANTABILITY AND FITNESS FOR A PARTICULAR PURPOSE, SHALL BE LIMITED TO THE DURATION OF THIS LIMITED WARRANTY, OTHERWISE THE REPAIR OR REPLACEMENT PROVIDED UNDER THIS EXPRESS LIMITED WARRANTY IS THE EXCLUSIVE REMEDY OF THE CONSUMER, AND IS PROVIDED IN LIEU OF ALL OTHER WARRANTIES, EXPRESS OR IMPLIED. IN NO EVENT SHALL MOTOROLA OR BINATONE BE LIABLE, WHETHER IN CONTRACT OR TORT (INCLUDING NEGLIGENCE) FOR DAMAGES IN EXCESS OF THE PURCHASE PRICE OF THE PRODUCT OR ACCESSORY, OR FOR ANY INDIRECT, INCIDENTAL, SPECIAL OR CONSEQUENTIAL DAMAGES OF ANY KIND, OR LOSS OF REVENUE OR PROFITS, LOSS OF BUSINESS, LOSS OF INFORMATION OR OTHER FINANCIAL LOSS ARISING OUT OF OR IN CONNECTION WITH THE ABILITY OR INABILITY TO USE THE PRODUCTS OR ACCESSORIES TO THE FULL EXTENT THESE

## DAMAGES MAY BE DISCLAIMED BY LAW.

Some jurisdictions do not allow the limitation or exclusion of incidental or consequential damages, or limitation on the length of an implied warranty, so the above limitations or exclusions may not apply to you. This Warranty gives you specific legal rights, and you may also have other rights that vary from one jurisdiction to another.

Products Covered	Length of Coverage
Consumer Products	<b>One (1) year</b> from the date of the Products, original purchase by the first consumer purchaser of the product.
Consumer Accessories	<b>Ninety (90) days</b> from the date of the Accessories, original purchase by the first consumer purchaser of the product.
Consumer Products and Accessories that are Repaired or Replaced	<b>The balance of the original warranty or for Ninety (90) days</b> from the date returned to the consumer, whichever is longer.

## Exclusions

**Normal Wear and Tear.** Periodic maintenance, repair and replacement of parts due to normal wear and tear are excluded from coverage.

**Batteries.** Only batteries whose fully charged capacity falls below 80% of their rated capacity and batteries that leak are covered by this Warranty.

**Abuse & Misuse.** Defects or damage that result from:  
 (a) improper operation, storage, misuse or abuse,

accident or neglect, such as physical damage (cracks, scratches, etc.) to the surface of the product resulting from misuse; (b) contact with liquid, water, rain, extreme humidity or heavy perspiration, sand, dirt or the like, extreme heat, or food; (c) use of the Products or Accessories for commercial purposes or subjecting the Product or Accessory to abnormal usage or conditions; or (d) other acts which are not the fault of MOTOROLA or BINATONE, are excluded from coverage.

**Use of Non-Motorola branded Products and Accessories.** Defects or damage that result from the use of Non-Motorola branded or certified Products or Accessories or other peripheral equipment are excluded from coverage.

**Unauthorized Service or Modification.** Defects or damages resulting from service, testing, adjustment, installation, maintenance, alteration, or modification in any way by someone other than MOTOROLA, BINATONE or its authorized service centers, are excluded from coverage.

**Altered Products.** Products or Accessories with (a) serial numbers or date tags that have been removed, altered or obliterated; (b) broken seals or that show evidence of tampering; (c) mismatched board serial numbers; or (d) nonconforming or non-Motorola branded housings, or parts, are excluded from coverage.

**Communication Services.** Defects, damages, or the failure of Products or Accessories due to any communication service or signal you may subscribe to or use with the Products or Accessories is excluded from coverage.

## ***How to Obtain Warranty Service or Other Information?***

To obtain service or information, please call:

US and Canada 1-888-331-3383

E-mail: [support@motorolastore.com](mailto:support@motorolastore.com)

You will receive instructions on how to ship the Products or Accessories at your expense and risk, to a BINATONE Authorized Repair Center.

To obtain service, you must include: (a) the Product or Accessory; (b) the original proof of purchase (receipt) which includes the date, place and seller of the Product; (c) if a warranty card was included in your box, a completed warranty card showing the serial number of the Product; (d) a written description of the problem; and, most importantly; (e) your address and telephone number.

These terms and conditions constitute the complete warranty agreement between you and BINATONE regarding the Products or Accessories purchased by you, and supersede any prior agreement or representations, including representations made in any literature publications or promotional materials issued by BINATONE or representations made by any agent employee or staff of BINATONE, that may have been made in connection with the said purchase.

## **FCC and IC regulations**

### **FCC Part 15**

**NOTE:** This equipment has been tested and found to comply with the limits for a Class B digital device, pursuant to Part 15 of the Federal Communications Commission (FCC) rules. These limits are designed to provide reasonable protection against harmful

interference in a residential installation. This equipment generates, uses and can radiate radio frequency energy and, if not installed and used in accordance with the instructions, may cause harmful interference to radio communications. However, there is no guarantee that interference will not occur in a particular installation. If this equipment does cause harmful interference to radio or television reception, which can be determined by turning the equipment off and on, the user is encouraged to try to correct the interference by one or more of the following measures:

- Reorient or relocate the receiving antenna.
- Increase the separation between the equipment and receiver.
- Connect the equipment into an outlet on a circuit different from that to which the receiver is connected.
- Consult the dealer or an experienced radio/TV technician for help.

Changes or modifications to this equipment not expressly approved by the party responsible for compliance could void the user's authority to operate the equipment.

This device complies with Part 15 of the FCC rules. Operation is subject to the following two conditions: (1) this device may not cause harmful interference, and (2) this device must accept any interference received, including interference that may cause undesired operation. Privacy of communications may not be ensured when using this device.

To ensure safety of users, the FCC has established criteria for the amount of radio frequency energy that can be safely absorbed by a user or bystander according to the intended usage of the product. This

product has been tested and found to comply with the FCC criteria.

This Class B digital apparatus complies with Canadian ICES-003.

CAN ICES-3(B)/NMB-3(B)

### **WARNING**

Changes or modifications, to this equipment not expressly approved by the party responsible for compliance could void the user's authority to operate the equipment.

The socket-outlet shall be installed near the equipment and shall be easily accessible.

### **Industry Canada**

This device complies with Industry Canada licence-exempt RSS standard(s): Operation is subject to the following Two conditions:(1) this device may not cause interference, and (2) this device must accept any interference, including interference that may cause undesired operation of the device.

The term "IC: " before the certification/registration number only signifies that the Industry Canada technical specifications were met. This product meets the applicable Industry Canada technical specifications.

Le présent appareil est conforme aux CNR d'Industrie Canada applicables aux appareils radio exempts de licence. L'exploitation est autorisée aux deux conditions suivantes : (1) l'appareil ne doit pas produire de brouillage, et (2) l'utilisateur de l'appareil doit accepter tout brouillage radioélectrique subi, même si le brouillage est susceptible d'en compromettre le fonctionnement.

## ***7. Technical Specifications***

LCD screen	4.0-inch
Video resolution	Up to FHD 1920*1080P
Lens	152° wide angle
Video format	MOV
Pictures resolution	Up to 12M pixels
Photo format	JPEG
Micro SD card	Up to 32G capacity, Class 10
Night vision	Supported
Mic and Speaker	Built-in
Power	5V DC
Battery	Li-polymer battery
Device dimensions	114x64x36mm
Mount dimensions	55x55x50mm
Supported operating system for file viewing	Windows XP and later, MAC OS





motorola

Manufactured, distributed or sold by Binatone Electronics International LTD., official licensee for this product.

MOTOROLA and the Stylised M Logo, are trademarks or registered trademarks of Motorola Trademark Holdings, LLC. and are used under license. All other trademarks are the property of their respective owners. © 2017 Motorola Mobility LLC. All rights reserved.



US\_EN Version 1.0  
Printed in China